

Rayson

Bluetooth® Module

Class1 BC04-ext Module

BTM-222

Features

- Bluetooth Ver. 2.0+EDR certification
- Transmit Power up to +18dBm(class1)
- Low current consumption:
Hold, Sniff, Park, Deep sleep mode
- 3.0V to 3.6V operation
- Full Bluetooth Data rate over UART and USB
- Support up to 7 ACL links and 3 SCO links
- Enhanced Data Rate(EDR) compliant
for both 2Mbps and 3Mbps modulation modes
- Interface: USB, UART&PCM(for voice codec)
- SPP firmware with AT commands
- RoHS Compliant
- Mini outline: 28.2 X 15.0 X 2.8 mm

Application

- Access point
- Domestic and Industrial applications
- Serial Adapter
- GPS, POS, Barcode Reader

Outline

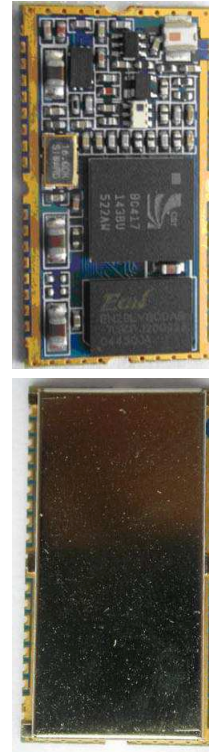

Block Diagram

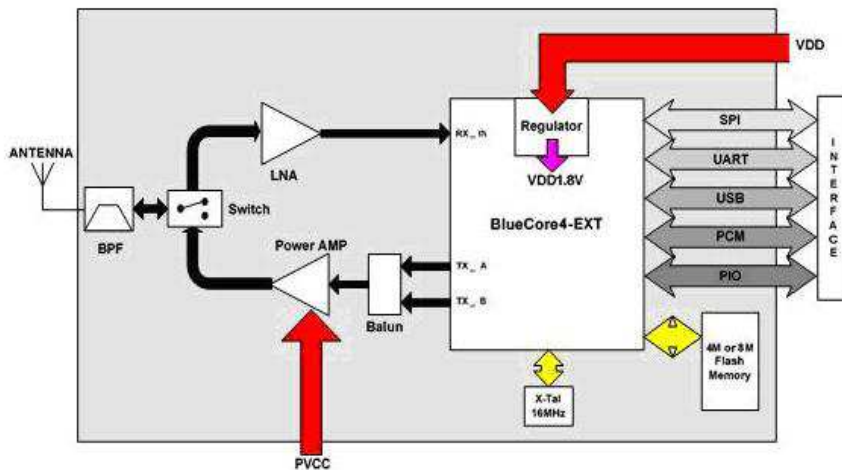

Electrical Characteristics

Absolute Maximum Ratings					
Parameter	Min.	Max.	Unit		
Storage Temperature	-40	+85	°C		
Supply Voltage(VDD)	2.7	3.6	DCV		
Supply Voltage(PVCC)	3.0	3.3	DCV		
Other Pin Voltage	Vss-0.4	VDD+0.4	DCV		
Recommended Operating Conditions					
Parameter	Min.	Max.	Unit		
Temperature	-10	+70	°C		
Supply Voltage for UART	3.0	3.6	DCV		
Supply Voltage for USB	3.0	3.6	DCV		
General Electrical Specification					
Parameter	Description	Min.	Typ.	Max.	Unit
Carrier Frequency		2.402		2.480	GHz
RF Output Power	Measured in 50ohm	15	16.5	18	dBm
RX sensitivity		-	-88	-86	dBm
Load Impedance	No abnormal Oscillation			5:1	
Input Low Voltage	RESET,UART,GPIO,PCM	-0.30	-	0.80	DCV
Input High Voltage	RESET,UART,GPIO,PCM	0.7VDD	-	VDD+0.3	DCV
Output Low Voltage	UART,GPIO,PCM	-	-	0.40	DCV
Output High Voltage	UART,GPIO,PCM	VDD-0.4	-	-	DCV
Average Current Consumption	Receive DM1		114		mA

Radio Characteristics - Basic Data Rate

Transmitter , VDD = 3.3V Temperature =+20°C						
	Frequency (GHz)	Min.	Typ.	Max.	Bluetooth Specification	Unit
RF transmit power	2.402	15	16.5	18	-6 to +20	dBm
	2.441	15	16.5	18		dBm
	2.480	15	16.5	18		dBm
Initial carrier frequency tolerance	2.402	-	12	25	±75	kHz
	2.441	-	10	25		kHz
	2.480	-	9	25		kHz
-20dB bandwidth for modulated carrier	2.402	-	890	1000	≤ 1000	kHz
	2.441	-	870	1000		kHz
	2.480	-	820	1000		kHz
Carrier Frequency Drift (single slot packet DH1)	2.402	-	±10	±20	≤25	kHz
	2.441	-	±10	±20		kHz
	2.480	-	±10	±20		kHz
Carrier Frequency Drift (five slot packet DH5)	2.402	-	±10	±20	≤40	kHz
	2.441	-	±10	±20		kHz
	2.480	-	±10	±20		kHz
Drift Rate	2.402	-	±7	±14	≤20	kHz/50µs
	2.441	-	±7	±14		kHz/50µs
	2.480	-	±7	±14		kHz/50µs
RF power control range		16	25	-	≥16	dB

$\Delta f1^{avg}$ "Maximum Modulation"	2.402	145	165	170	140< $\Delta f1^{avg}$ <175	kHz
	2.441	145	165	170		kHz
	2.480	145	165	170		kHz
$\Delta f2^{maz}$ "Minimum Modulation"	2.402	115	150	-	>115	kHz
	2.441	115	150	-		kHz
	2.480	115	150	-		kHz
Adjacent channel transmit power $F=F_0\pm 2\text{MHz}$		-	-35	-20	≤ -20	dBm
Adjacent channel transmit power $F=F_0\pm 3\text{MHz}$		-	-45	-40	≤ -40	dBm
Adjacent channel transmit power $F>F_0+3\text{MHz}$		-	-50	-40	≤ -40	dBm
Adjacent channel transmit power $F<F_0-3\text{MHz}$		-	-50	-40	≤ -40	dBm
Receiver , VDD = 3.3V Temperature =+20°C						
	Frequency (GHz)	Min.	Typ.	Max.	Bluetooth Specification	Unit
Sensitivity at 0.1% BER (Single slot packets)	2.402	-	-88	-86	≤ -70	dBm
	2.441	-	-88	-86		dBm
	2.480	-	-88	-86		dBm
Sensitivity at 0.1% BER (Multi slot packets)	2.402	-	-88	-86	≤ -70	dBm
	2.441	-	-88	-86		dBm
	2.480	-	-88	-86		dBm
Maximum received signal level at 0.1% BER	2.402	-20	-10	-	≥ -20	dBm
	2.441	-20	-10	-		dBm
	2.480	-20	-10	-		dBm
C/I co-channel		-	6	11	≤ 11	dB
Adjacent channel selectivity C/I $F=F_0+1\text{ MHz}$		-	-4	-	≤ 0	dB
Adjacent channel selectivity C/I $F=F_0-1\text{MHz}$		-	-4	-	≤ 0	dB
Adjacent channel selectivity C/I $F=F_0+2\text{ MHz}$		-	-38	-	≤ -30	dB
Adjacent channel selectivity C/I $F=F_0-2\text{MHz}$		-	-23	-	≤ -20	dB
Adjacent channel selectivity C/I $F>F_0+3\text{ MHz}$		-	-45	-	≤ -40	dB
Adjacent channel selectivity C/I $F<F_0-5\text{ MHz}$		-	-44	-	≤ -40	dB
Adjacent channel selectivity C/I $F=F_{image}$		-	-22	-	≤ -9	dB
$F_0 = 2441\text{ MHz}$						
Maximum level of intermodulation interference (n=5)			-30		≥ -39	dBm

Radio Characteristics – Enhanced Data Rate

Transmitter , VDD = 3.3V Temperature =+20°C						
	Frequency (GHz)	Min.	Typ.	Max.	Bluetooth Specification	Unit
Maximum RF transmit power ^(note)	2.402	-	6	-	-6 to +20	dBm
	2.441	-	6	-		dBm
	2.480	-	7	-		dBm
Relative transmit power		-	-1.6	-	-4 to +1	dB
$\pi/4$ DQPSK Maximum carrier frequency stability w_0		-	2	-	$\leq \pm 10$ for all blocks	kHz
$\pi/4$ DQPSK Maximum carrier frequency stability w_i		-	6	-	$\leq \pm 75$ for all packets	kHz
$\pi/4$ DQPSK Maximum carrier frequency stability $ w_0 + w_i $		-	8	-	$\leq \pm 75$ for all blocks	kHz
8 DPSK Maximum carrier frequency stability w_0		-	2	-	$\leq \pm 10$ for all blocks	kHz

8 DPSK		-	6	-	$\leq \pm 75$ for all packets	kHz
Maximum carrier frequency stability w_i		-	8	-	$\leq \pm 75$ for all blocks	kHz
8 DPSK		-	8	-	$\leq \pm 75$ for all blocks	kHz
Maximum carrier frequency stability $ w_0 + w_i $		-	8	-	$\leq \pm 75$ for all blocks	kHz
$\pi/4$ DQPSK Modulation Accuracy	RMS DVEM	-	7	-	≤ 20	%
	99% DEVM	-	13	-	≤ 30	%
	Peak DEVM	-	19	-	≤ 35	%
8 DPSK Modulation Accuracy	RMS DVEM	-	7	-	≤ 13	%
	99% DEVM	-	13	-	≤ 20	%
	Peak DEVM	-	17	-	≤ 25	%
In-band spurious emissions	$F > F_0 + 3$ MHz	-	<-50	-	≤ -40	dBm
	$F < F_0 - 3$ MHz	-	<-50	-	≤ -40	dBm
	$F = F_0 - 3$ MHz	-	-46	-	≤ -40	dBm
	$F = F_0 - 2$ MHz	-	-34	-	≤ -20	dBm
	$F = F_0 - 1$ MHz	-	-35	-	≤ -26	dBm
	$F = F_0 + 1$ MHz	-	-35	-	≤ -26	dBm
	$F = F_0 + 2$ MHz	-	-31	-	≤ -20	dBm
$F = F_0 + 3$ MHz	-	-33	-	≤ -40	dBm	
EDR Differential Phase Encoding		No Errors			≥ 99	%
Receiver , VDD = 3.3V Temperature =+20°C						
	Modulation	Min.	Typ.	Max.	Bluetooth Specification	Unit
Sensitivity at 0.1% BER	$\pi/4$ DQPSK	-	-87	-	≤ -70	dBm
	8 DPSK	-	-78	-	≤ -70	dBm
Maximum received signal level at 0.1% BER	$\pi/4$ DQPSK	-	-8	-	≥ -20	dBm
	8 DPSK	-	-10	-	≥ -20	dBm
C/I co-channel at 0.1% BER	$\pi/4$ DQPSK	-	10	-	$\leq +13$	dB
	8 DPSK	-	19	-	$\leq +21$	dB
Adjacent channel selectivity C/I $F = F_0 + 1$ MHz	$\pi/4$ DQPSK	-	-10	-	≤ 0	dB
	8 DPSK	-	-5	-	$\leq +5$	dB
Adjacent channel selectivity C/I $F = F_0 - 1$ MHz	$\pi/4$ DQPSK	-	-11	-	≤ 0	dB
	8 DPSK	-	-5	-	$\leq +5$	dB
Adjacent channel selectivity C/I $F = F_0 + 2$ MHz	$\pi/4$ DQPSK	-	-40	-	≤ -30	dB
	8 DPSK	-	-40	-	≤ -25	dB
Adjacent channel selectivity C/I $F = F_0 - 2$ MHz	$\pi/4$ DQPSK	-	-23	-	≤ -20	dB
	8 DPSK	-	-20	-	≤ -13	dB
Adjacent channel selectivity C/I $F = F_0 + 3$ MHz	$\pi/4$ DQPSK	-	-45	-	≤ -40	dB
	8 DPSK	-	-45	-	≤ -33	dB
Adjacent channel selectivity C/I $F = F_0 - 5$ MHz	$\pi/4$ DQPSK	-	-45	-	≤ -40	dB
	8 DPSK	-	-45	-	≤ -33	dB
$F_0 = 2405, 2441, 2477$ MHz						
Adjacent channel selectivity C/I $F = F_{\text{image}}$	$\pi/4$ DQPSK		-20		≤ -7	dB
	8 DPSK		-15		≤ 0	dB

Note :

Measurement made using a POWER_TABLE entry of TX_PRE 80, INT PA63, EXT PA255. This ensures that the Bluetooth requirements for ACP and those defined by the FCC and ETSI are satisfied over the operating temperature range of -5°C to +45°C. Although the design is capable of generating in excess of +18dBm, regulatory compliance over the full temperature range of -5°C to +45°C will not be satisfied if the transmit power approaches this value.

BTM-222 Pin Function

Pin No.	Pin Name	Pin Type	Description
1	GND	GND	Common ground
2	PVCC	Power	Power Amp. Power Supply(3.3V)
3	AIO(0)	Bi-directional	Programmable I/O terminal , 32KHz sleep clock input
4	AIO(1)	Bi-directional	Programmable I/O terminal
5	PIO(0)	Bi-directional	Programmable I/O terminal, RX Enable
6	PIO(1)	Bi-directional	Programmable I/O terminal, TX Enable
7	PIO(2)	Bi-directional	Programmable I/O terminal, USB_PULL_UP, CLK_REQ_OUT
8	PIO(3)	Bi-directional	Programmable I/O terminal, USB_WAKE_UP, CLK_REQ_IN
9	PIO(4)	Bi-directional	Programmable I/O terminal, USB_ON, BT_Priority/Ch_Clk output for co-existence signalling
10	GND	GND	Common ground
11	PIO(5)	Bi-directional	Programmable I/O terminal, USB_DETACH, BT_Active output for co-existence signalling
12	PIO(6)	Bi-directional	Programmable I/O terminal, CLK_REQ, WLAN_Active/Ch_Data input for for co-existence signalling
13	PIO(7)	Bi-directional	Programmable I/O terminal
14	PIO(8)	Bi-directional	Programmable I/O terminal
15	PIO(9)	Bi-directional	Programmable I/O terminal
16	RESET	CMOS input	Reset input of module, Active low reset
17	VCC	Power	Module power supply input
18	GND	GND	Common ground
19	GND	GND	Common ground
20	USB_DP	Bi-directional	USB data plus
21	USB_DN	Bi-directional	USB data minus
22	PCM_SYNC	Bi-directional	Synchronous data sync
23	PCM_IN	CMOS input	Synchronous data input
24	PCM_OUT	CMOS output	Synchronous data output
25	PCM_CLK	Bi-directional	Synchronous data clock
26	UART_RX	CMOS input	UART data input
27	UART_TX	CMOS output	UART data output
28	UART_RTS	CMOS output	UART request to send(active low)
29	GND	GND	Common ground
30	UART_CTS	CMOS input	UART clear to send(active low)
31	SPI_MOSI	CMOS input	Serial Peripheral Interface data input
32	SPI_CSB	CMOS input	Chip select for Synchronous Serial Interface(active low)
33	SPI_CLK	CMOS input	Serial Peripheral Interface clock
34	SPI_MISO	CMOS output	Serial Peripheral Interface data output
35	PIO(11)	Bi-directional	Programmable I/O terminal
36	PIO(10)	Bi-directional	Programmable I/O terminal
37	RF_IO	Analogue	Antenna interface
38	GND	GND	Common ground

SPP AT Command sets

A (Establish connection)	When it' s in master mode. This command establish a connection. When it' s in slave mode, the command will be rejected.	
	<i>Modifiers</i>	<i>Description</i>
	A	Connect to a Bluetooth device (It' s only available when "ATD=xxxxxxxxxxx" assigned)
	A1~A8	Connect to a Bluetooth neighborhood device 1~8 (ATF? Result)
B (Display local BD address)	This command display the local device BD address	
	<i>Modifiers</i>	<i>Description</i>
	B?	Inquire the Local BD address
D (Set Remote BD address)	For security purpose, We can specifies the unique remote device can be connected. In master role, it automatically inquire and search the slave even the slave is undiscoverable. In slave role, the command should be as a filter condition to accept the master' s inquiry.	
	<i>Modifiers</i>	<i>Description</i>
	D=xxxxxxx xxxxx	"xxxx-xx-xxxxxx" is 12 digit hex symbol
	D0 (Default)	Clear Remote BD address setting, inquire any slave in master mode or accept any master in slave mode.
	D?	Inquire the Remote BD address setting
E (Local Echo)	This command specifies whether the device should echo characters received from the UART back to the DTE/DCE.	
	<i>Modifiers</i>	<i>Description</i>
	E0	Command characters received from the UART are not echoed back to the DTE/DCE.
	E1 (Default)	Command characters received from the UART are echoed back to the DTE/DCE.
	E?	Inquire the current setting
F (Find Bluetooth device)	This command is used to find any bluetooth device in neighborhood within 60 seconds timeout. If any device is found, its name and address will be listed. The search ends with a message "Inquiry ends, xx device(s) found." This command is available only when the adaptor is in the master role.	
	<i>Modifiers</i>	<i>Description</i>
	F?	Inquire scan Bluetooth neighborhood devices.
H (Discoverable Control)	This command specifies whether the device could be discovered by remote master device. note : waiting for 15 seconds afert ATH1 command to take the effect	
	<i>Modifiers</i>	<i>Description</i>
	H0	The device enters undiscoverable mode. If a pair have been made, the original connection could be connected again. But other remote master device can not discovery this device.
	H1 (Default)	The device enters discoverable mode.
	H?	Inquire the current setting
_	This command is used to Inquiry the F/W version	

(Information)	<i>Modifiers</i>	<i>Description</i>
	I?	Inquire the version Codes
K (Stop bits setting)	This command is used to specify one or two stop bits of COM port	
	<i>Modifiers</i>	<i>Description</i>
	K0 (Default)	One Stop bit
	K1	Two stop bits
	K?	Inquire the current setting
L (Baud Rate Control)	This command is used to specify the baud rate of COM port	
	<i>Modifiers</i>	<i>Description</i>
	L0	4800bps
	L1	9600bps
	L2 (Default)	19200bps
	L3	38400bps
	L4	57600bps
	L5	115200bps
	L6	230.4Kbps
	L7	460.8Kbps
L?	Inquire the current setting	
M (Parity bits setting)	This command is used to specify the parity bit setting of COM port	
	<i>Modifiers</i>	<i>Description</i>
	M0 (Default)	None Parity bit.
	M1	Odd parity setting.
	M2	Even parity setting
	M?	Inquire the current setting
N (Set device name)	We can specifies the device a friendly name using 0 to 9, A to Z, a to z, space and - , which are all valid characters. Note that "firs space or -, last space or - isn' t permitted". The default name is "Serial Adaptor"	
	<i>Modifiers</i>	<i>Description</i>
	N=xxxxx	"xxxxx" is a character string, maxima length is 16
	D?	Inquire the device name
O (Auto connect setting)	When it' s in master mode .The command is used to enable/disable auto-connection feature. When it' s in slave mode, the command will be rejected.	
	<i>Modifiers</i>	<i>Description</i>
	O0 (Default)	Automatically connecting to a device which is assigned in "ATD" or any available device if "ATD" was not assigned.
	O1	Disable auto-connection feature, user should manually use "ATA" command to connect a remote device.
	O?	Inquire the current setting
P (Set PIN code)	This command specifies the PIN number. It control to off the PIN code authorization that allow to establish a connection without PIN code. Default PIN number is "1234"	
	<i>Modifiers</i>	<i>Description</i>
	P=xxxx	"xxxx" is 4-8 digit string

	(Default)	
	P0	Turn off the PIN code authorization
	P?	Inquire the current PIN number
Q (Result Code Suppression)	The command is used to determine if result Codes should be sent to the DTE/DCE. When result Codes are suppressed, the device does not generate any characters in response to the completion of a command or when an event occurs. Four Result Codes : OK,CONNECT,DISCONNECT,ERROR	
	<i>Modifiers</i>	<i>Description</i>
	Q0 (Default)	The device will send Result Codes to the DTE/DCE.
	Q1	The device will not send Result Codes to the DTE/DCE.
	Q?	Inquire the current setting
R (Set Role)	This command specifies whether the device could be master or slave device. If change the role, the adaptor will warm start and clear all paired addresses.	
	<i>Modifiers</i>	<i>Description</i>
	R0	The device as master role.
	R1 (Default)	The device as slave role.
	R?	Inquire the current setting
U (F/W upgrade)	This command will prompt "Enter DFU mode, Are you sure (y/n)?" message, then press Y to confirm the command. Then you should connect USB cable to PC and run DFU wizard. (DFU wizard please contact us www.rayson.com)	
	<i>Modifiers</i>	<i>Description</i>
	U=pass word	Pass word = RaysonUpgrade ,Go into Upgrade F/W Mode
Z (Application setting)	Restore different application setting and warm start.	
	<i>Modifiers</i>	<i>Description</i>
	Z0	Restore factory default setting (19200bps, slave ...)
	Z?	Inquire the current setting

The factory settings of UART are as follows:

- Baud rate: 19200 bps
- Data bit: 8
- Parity: none
- Stop bit: 1
- Flow control: H/W or none
- Others: Please refer to AT Command Sets.

BTM-22x Dimension

Dimension

Unit : mm

